

**Solving the  
in-Building Challenge  
with  
Residential Gateways  
and Femtocells**

**Dr. Mehmet Unsoy  
Partner, Cartagena Capital**

**Eric Teissandier  
CEO, Bewan**

**December 4<sup>th</sup>, 2008**

**Next Generation Networks &  
Basestations Conference**

**Dallas, Texas**

# *Dr. Mehmet Unsoy*

- Highly experienced telecommunications technology executive with 30+ years experience in the data, IP and wireless industries
- Partner at Cartagena Capital, a global investment banking boutique, focused on telecom, specifically wireless companies
- Ex-CTO/ CIO, Vice President/ Chief Wireless Architect responsible for O2 (UK, Germany, Ireland and The Netherlands)
- Ex-VP Mobile Multimedia Architecture, British Telecom (UK)
- Former Director Wireless Internet, Nortel Networks – Asia/ Pacific, US and Global (US, Japan)
- Former R&D Director at Bell-Northern Research (Canada)
- Ph.D., University of Waterloo (Canada) and BSEE degree from METU in Ankara



bewan

# *Cartagena Capital*

- Investment banking boutique <http://www.cartagena-capital.com>
- Headquartered in Munich, Germany, with partners in Munich, Paris, Helsinki and Dallas, Texas
- Focus on Telecom sector, with special emphasis on broadband and wireless markets
- Key services: Mergers and Acquisitions (M&A) and Fundraising
- Working on a number of transactions in various areas:
  - ❖ Broadband / IPTV
  - ❖ FMC / Mobile VoIP
  - ❖ Mobile Video / TV
  - ❖ Mobile Security / Mobile Signature
  - ❖ RFID and M2M

# *Bewan*

- Founded in 1996
- Headquartered near Paris, France
- Privately owned by :
  - ❖ Founders and employees
  - ❖ 2 major French VCs (Seventure Partners, Aurel NextStage – 23.5%)
- 49 people based in France / 1 person in Taiwan
- High-end residential and SoHo broadband gateway solutions for all access technologies
- Dual market approach:
  - ❖ Telco & ISP in EMEA
  - ❖ Retail distribution in France for routers and accessories (Wi-Fi, PLC)
- More than 3 million units sold (directly or through licensing)



# *Outline*

**1.**

**Broadband Growth and Home Gateways**

**2.**

**FMC, FMS and Wireline Technologies within the Home**

**3.**

**Voice over WiFi and 3G Femtocells**

**4.**

**Multi-play Home Gateway Requirements**

**5.**

**Bewan Architecture and Products**



**bewan**



# Growth in Broadband Households

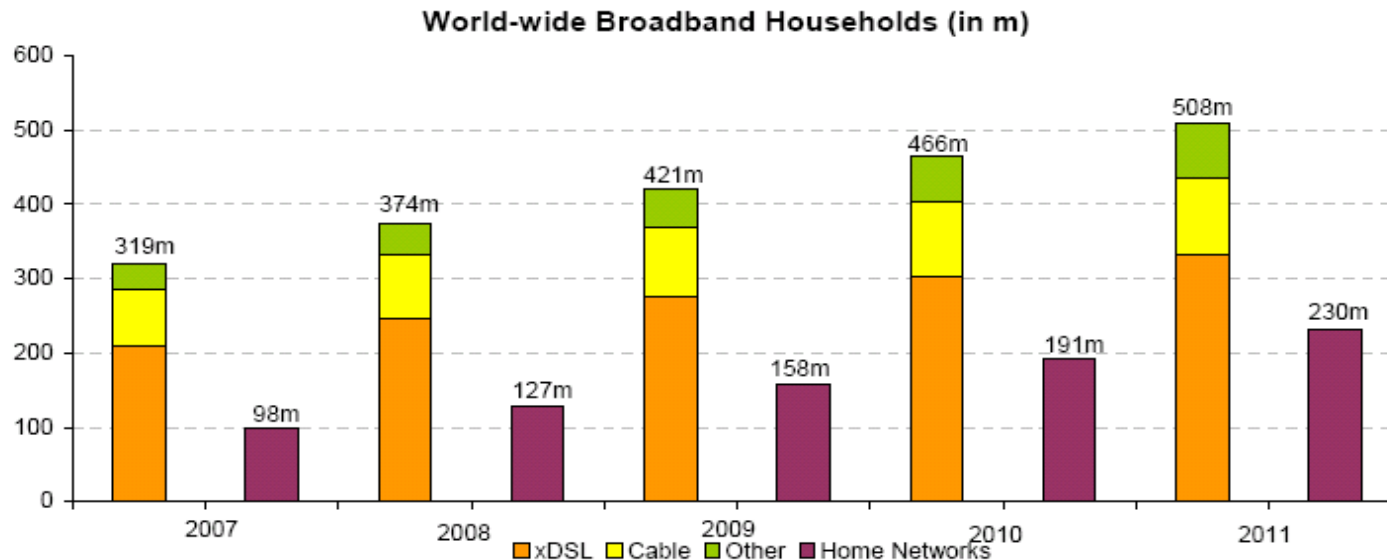

- Broadband connected households are forecasted to grow from 374 million in 2008 to 508 million in 2011 – About 67 million new subscribers in 2008
- xDSL will continue to remain the main access technology at 65% of all connections
- Home networks worldwide are expected to grow from 98 million in 2007 (30% of broadband HH) to 230 million in 2011 (45% of HH) - 24% CAGR

# From Modems to Multi-Play Home Gateways

## Increasing Software/Hardware Complexity

2000	2002	2004	2006	2008
Modem	Modem and four port Ethernet router	Modem; 4-port Ethernet wired 802.11 wireless router; firewall	Modem; four-port Ethernet wired 802.11 wireless router; firewall; <b>VoIP ports; support for MoCA or HomePlug, QoS, TR-069, parental control, MIMO and remote management and configuration</b>	Modem; four-port Ethernet wired 802.11 wireless router; firewall; VoIP ports; support for MoCA or HomePlug, QoS, TR-069 and <b>other DSL forum standards</b> , parental control, MIMO and <b>802.11n, basic home control and automation</b> ; and remote management and configuration

*Increasing Complexity*



bewan

Source: Light Reading



# Triple Play Gateways in France



- France is one of the most advanced markets in Europe and
- By Sep 2008, 10.5 million French homes have Triple Play Gateways, out of a total of 12.4 million DSL households (84% penetration)



# *Fixed Mobile – Convergence/ Substitution?*

- Almost 1/3<sup>rd</sup> of all calls made from homes are made on mobile phones
- In fact, in the U.S., now almost 20% of households do not have fixed line phones, and rely on mobile phones to make and receive calls
- Same is true for businesses: over 30% of all employees' calls are made from mobile phones
- All lead to analyst predictions of FMC market growth with annual growth rate of 170% between 2008 and 2011.

# *Fixed Mobile Convergence (FMC) & Fixed Mobile Substitution (FMS)*

## **Fixed to Mobile Convergence (FMC)**

- A way to provide seamless connectivity between cellular network and fixed wired network
- Service to a handset irrespective of whether the user is on either network, and to switch between them seamless
- Fixed network operators have been the first to promote FMC



## **Fixed to Mobile Substitution (FMS)**

- Tendency of consumers and businesses to increasingly substitute cellular telephones for fixed wired land-line communication
- Mobile operators have been successfully promoting FMS to grow their business, and will continue to do so



**bewan**



# *Connectivity options within the home*

- There are several technologies used within the home for distribution of traffic, such as
  - ❖ telephone wiring,
  - ❖ coax cable, and
  - ❖ various wireless choices
  
- However, for mobile voice, within the home, there are basically two wireless technology choices:
  - ❖ VoIP over Wi-Fi, and
  - ❖ Femtocells

# Who Favors Which Technology?

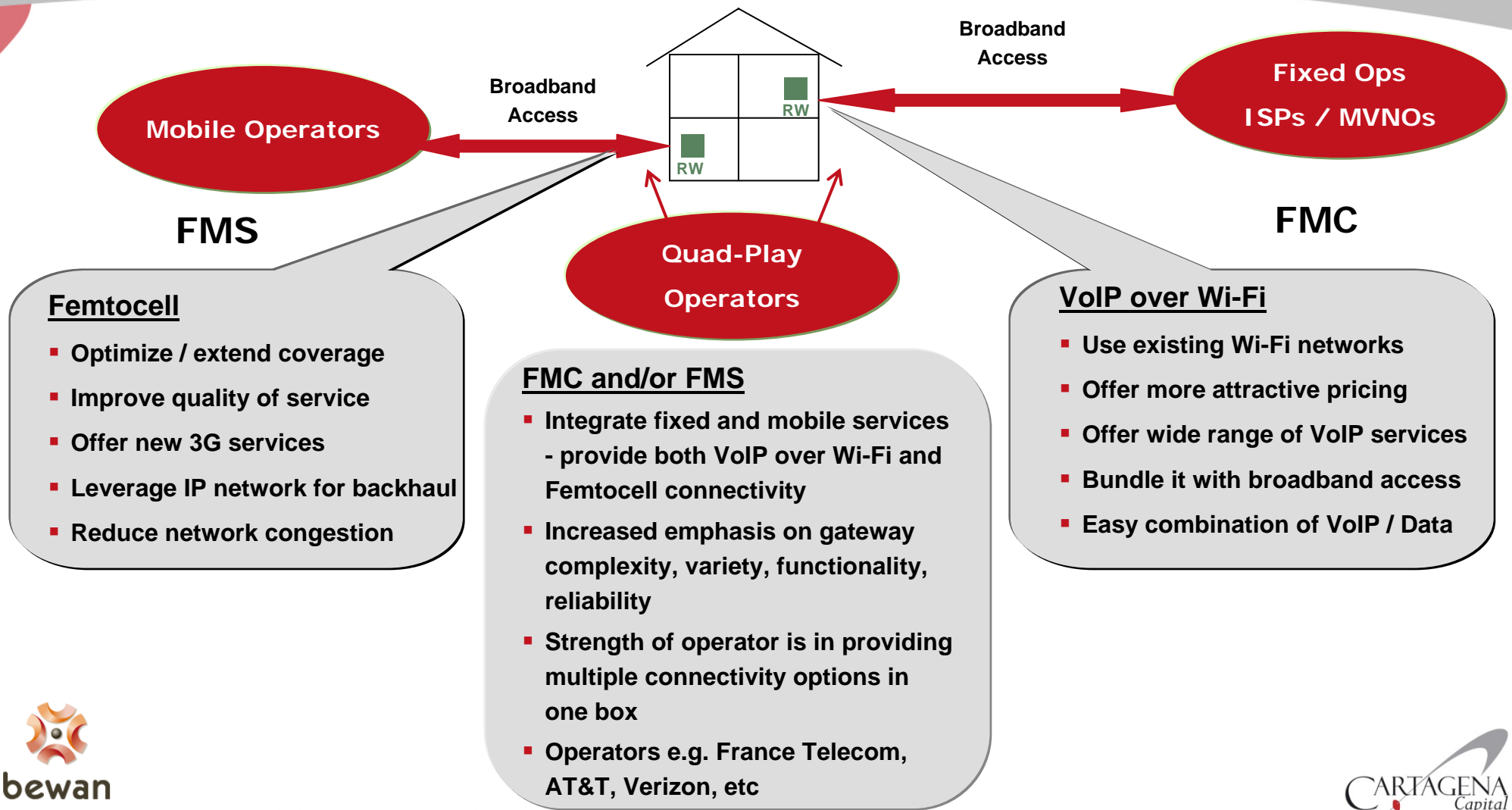

# Multi-Play Gateways for Evolving Access Technologies

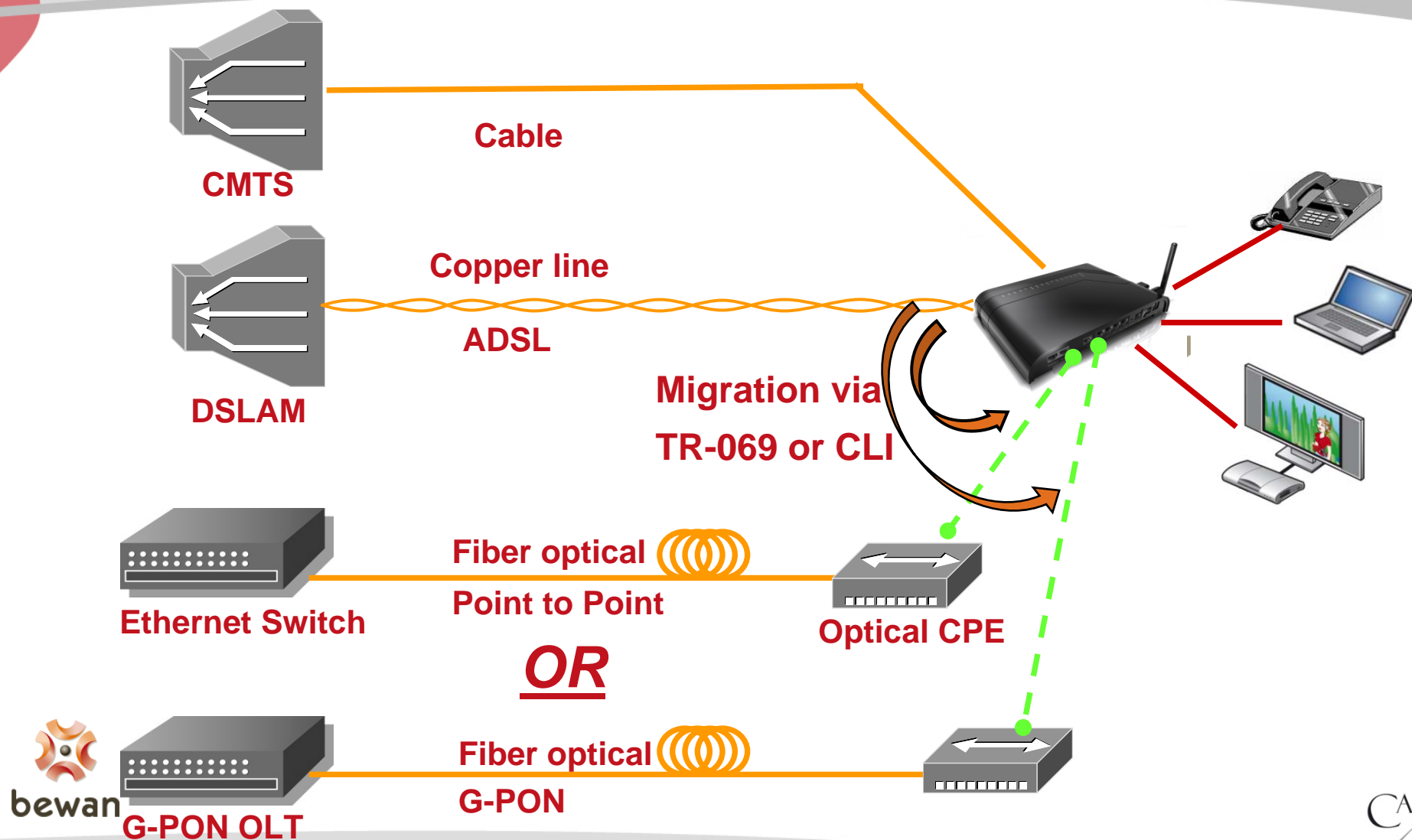

# Quad-Play Gateway with Voice over Wi-Fi

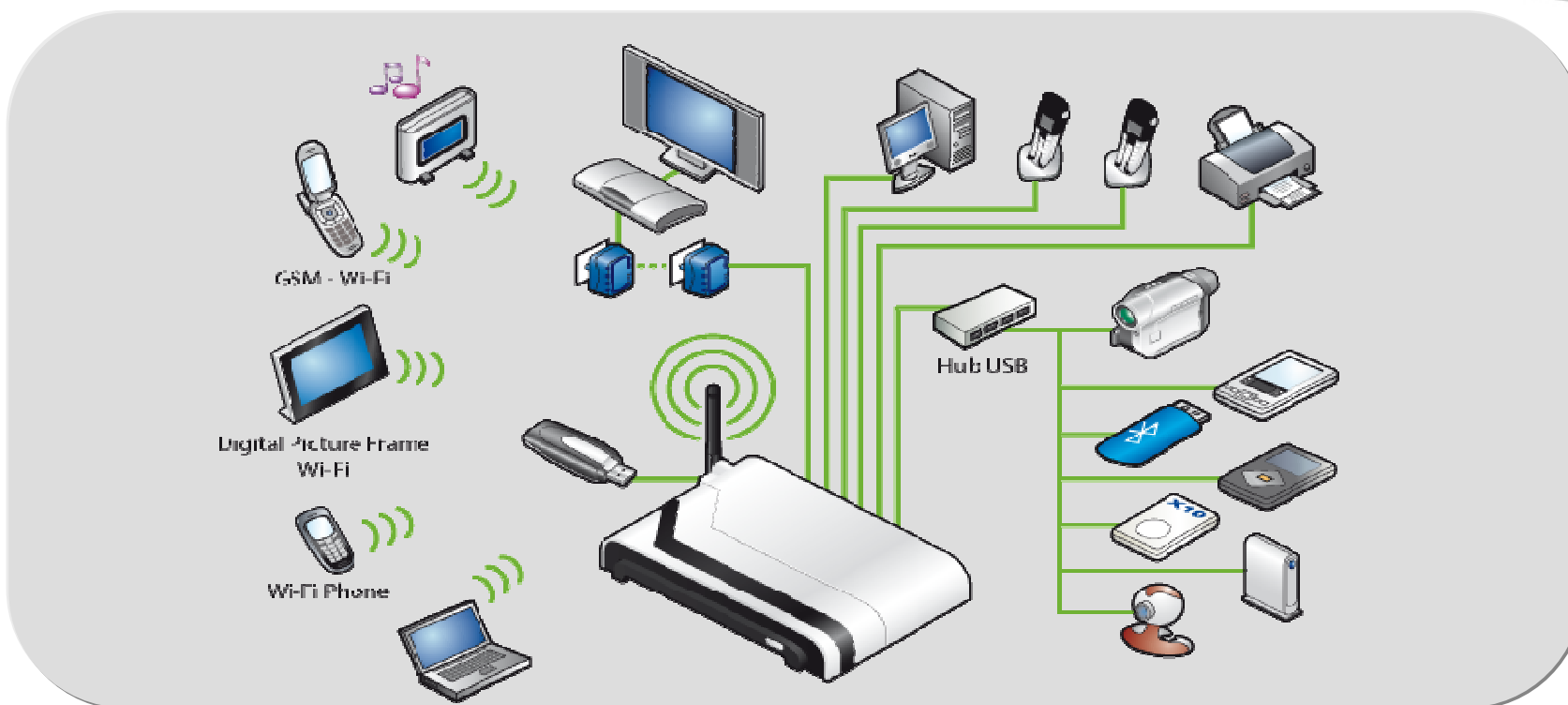

- The home gateway enables multiple services within the home since it can be connected to various equipment over Wi-Fi
- Moreover, it also serves as an on-line portal for storing and sharing music, photos etc.

# *Residential Gateway with 3G Femtocell*



## **The quad-play gateway can be extended to provide 3G connectivity with a Femtocell access point**

Features include:

- 3G and VoIP calls
- Wi-Fi 802.11b/g/n including Multi SSID with Hotspot
- IPTV support
- Support multiple media applications e.g. webcam, home automation, home security, printer sharing, Bluetooth dongle, Storage
- Personal embedded web server for remote access
- TR069 remote management for operators

**Residential Femtocell Gateways enable operators to extend and improve 3G coverage and capacity in a home or small office environment, via the existing 3G handsets**

# Multi-Play Gateway for SOHO

- Ability to strengthen in-building coverage
- IP-PBX with advanced features
- 3G and VoIP calling capability
- Wi-Fi a/b/g/n hotspot for guests
- Secured solution – VPN server
- Ability to provide webcam surveillance
- Remote management of office
- Central document sharing and print sharing

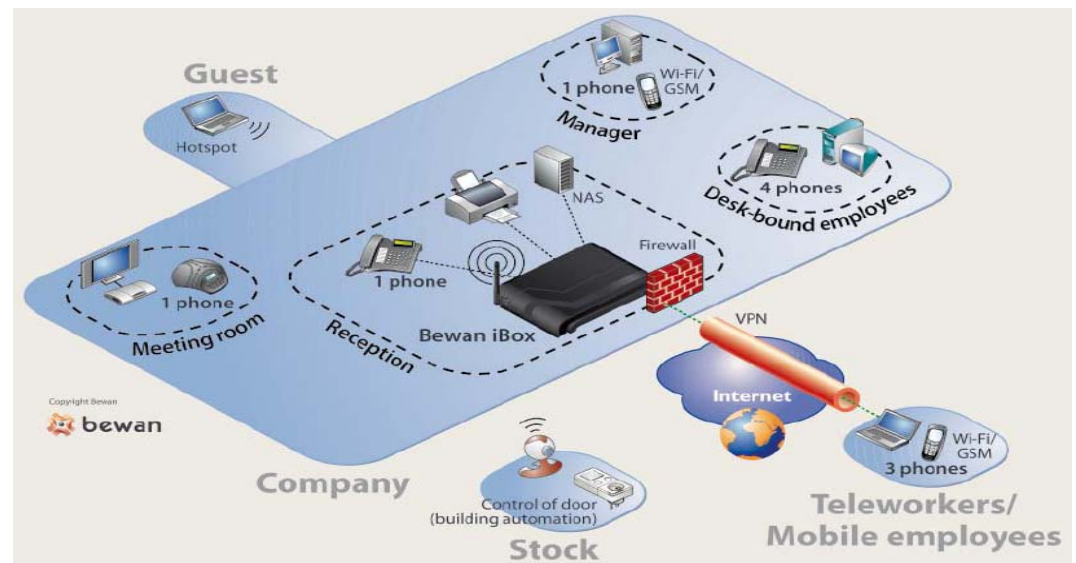

# *Implications for Home gateways*

<b>Feature</b>	<b>Gateway Architecture Characteristics</b>
<b>Flexibility</b>	<b>Ownership of hardware abstraction layer</b>
<b>Complexity</b>	<b>Layered architecture</b>
<b>Reliability</b>	<b>Multiple chip suppliers</b>

# Bewan Architecture for Multi-Play Gateways

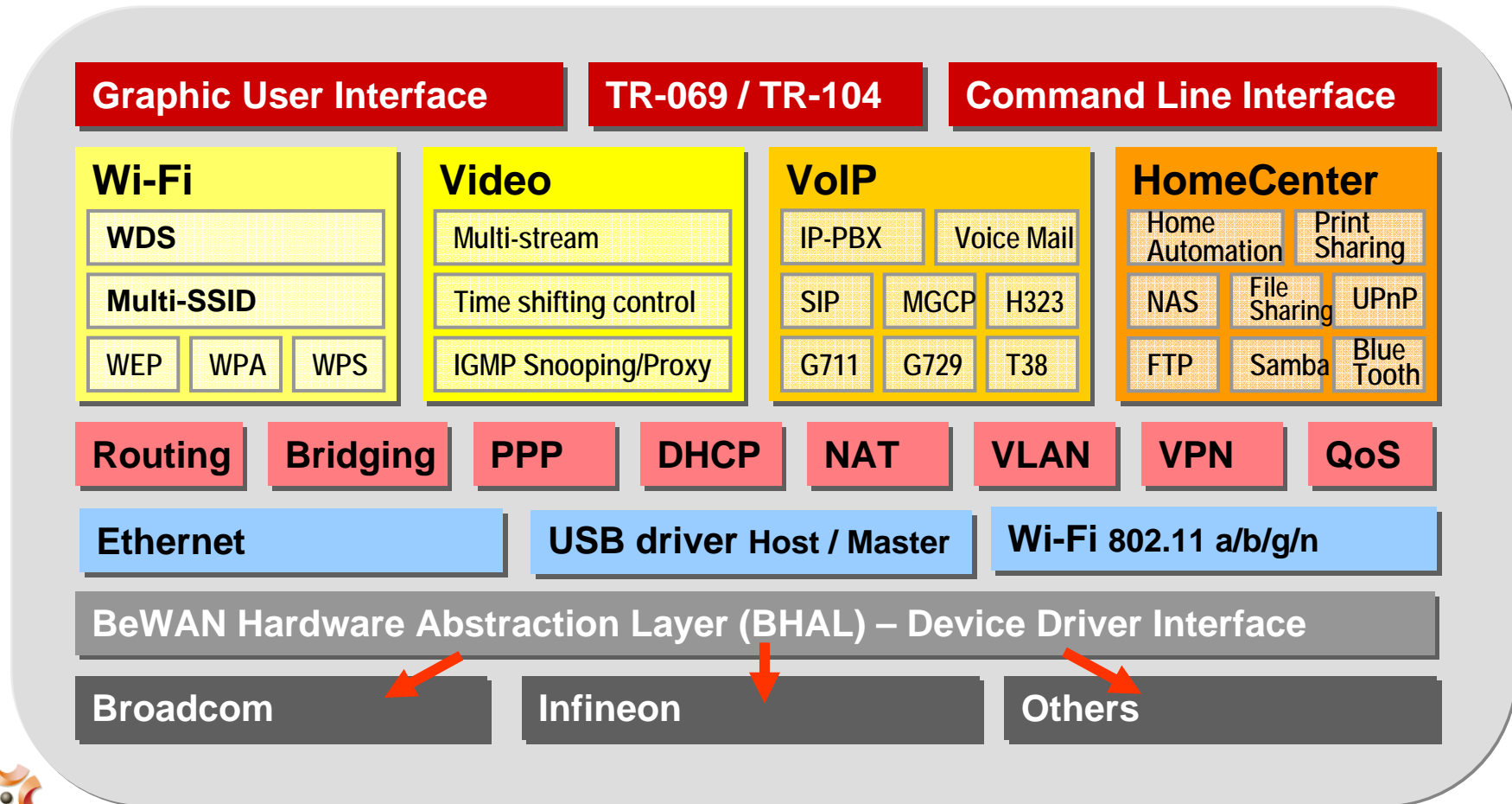

# Conclusions

- Broadband access to home will continue to grow via multiple access technologies; Multi-Play Home Gateways are increasing their penetration
- VoIP over Wi-Fi and 3G Femtocell will be the two major wireless technologies at Home
- Quad-Play Home Gateways may need to support both wireless technologies at Home: 3G Femtocells and VoIP over Wi-Fi
- Home Gateways need to provide a layered architecture with abstraction layers to accommodate these diverse technologies and growing number of services
- Bewan Home Gateway products are based on such architecture and offer wide range of technologies and growing number of services

# Questions?

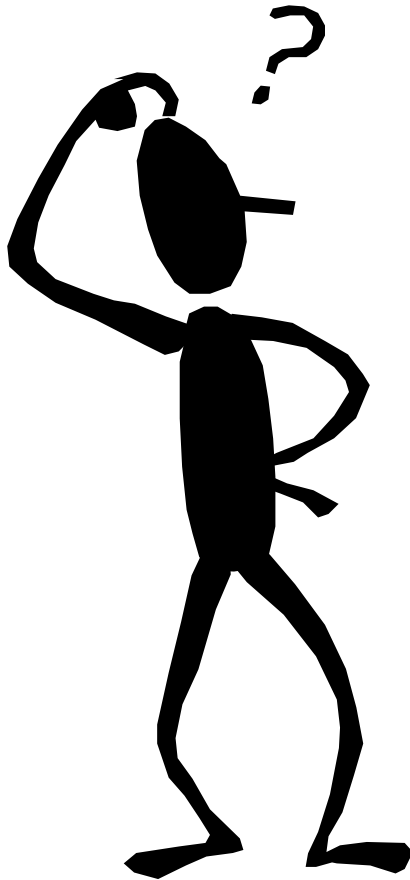

**Contact:**

**Dr. Mehmet Unsoy**

**Partner**

**Cartagena Capital GmbH**

**Phone: +1 972 818-2923**

**Mobile: +1 469 358-5302**

**Web: [www.cartagena-capital.com](http://www.cartagena-capital.com)**

**E-Mail: [mehmet@cartagena-capital.com](mailto:mehmet@cartagena-capital.com)**



**bewan**

