

BT Wireless VoIP Plans

Dr. Mehmet Unsoy
Vice President
Chief Wireless Architect
BT Wireless
mehmet.unsoy@bt.com

Outline

- BT Wireless Business Objectives
- BT Wireless Technology Roadmap
- Mobile Network Evolution
- BT Wireless perspective on VoIP
- Technology Collaborations

Top Level BT Wireless Objectives

Overall Objective:

Being the best personal communication company in the world

Supporting Objectives:

- **Delight the customer**
 - Be the preferred choice of operator
 - Know the customer, and how to meet & exceed their needs
- **Grow the Business**
 - Increase our existing business
 - Explore new business opportunities
- **Drive Up Revenues**
 - Acquire & retain high value customers
 - Deploy innovative products & services
- **Drive Down Costs**
 - Use economies of scale & cost-effective options
 - Deploy efficient networks & technology

Technology Vision

“To provide best in class technology services & expertise, and help to create the best personal communication company in the world”

Devices	
<ul style="list-style-type: none"> • Ensuring supply • Innovative Technology 	<ul style="list-style-type: none"> • Alignment for global services
Services	
<ul style="list-style-type: none"> • Common/shared platforms • Service Portability 	<ul style="list-style-type: none"> • Service Enablers • APIs for 3rd party/VNOs
Radio Access	
<ul style="list-style-type: none"> • 2G optimisation • Contain 2G investment 	<ul style="list-style-type: none"> • Early 3G launch • BT wireless procurement for 3G
Core Network	
<ul style="list-style-type: none"> • Leverage common core across JVs 	<ul style="list-style-type: none"> • Launch early, evolve to all-IP • Ensuring IP meets requirements

Network Management & IT Systems

- Buy not build
- Strategic back end platforms
- Best of breed tools
- Middleware for integration / flexibility
- Alignment to TMF open architecture for interworking
- Common platforms for new services

3G Launch

Release 99; Launch by 2002

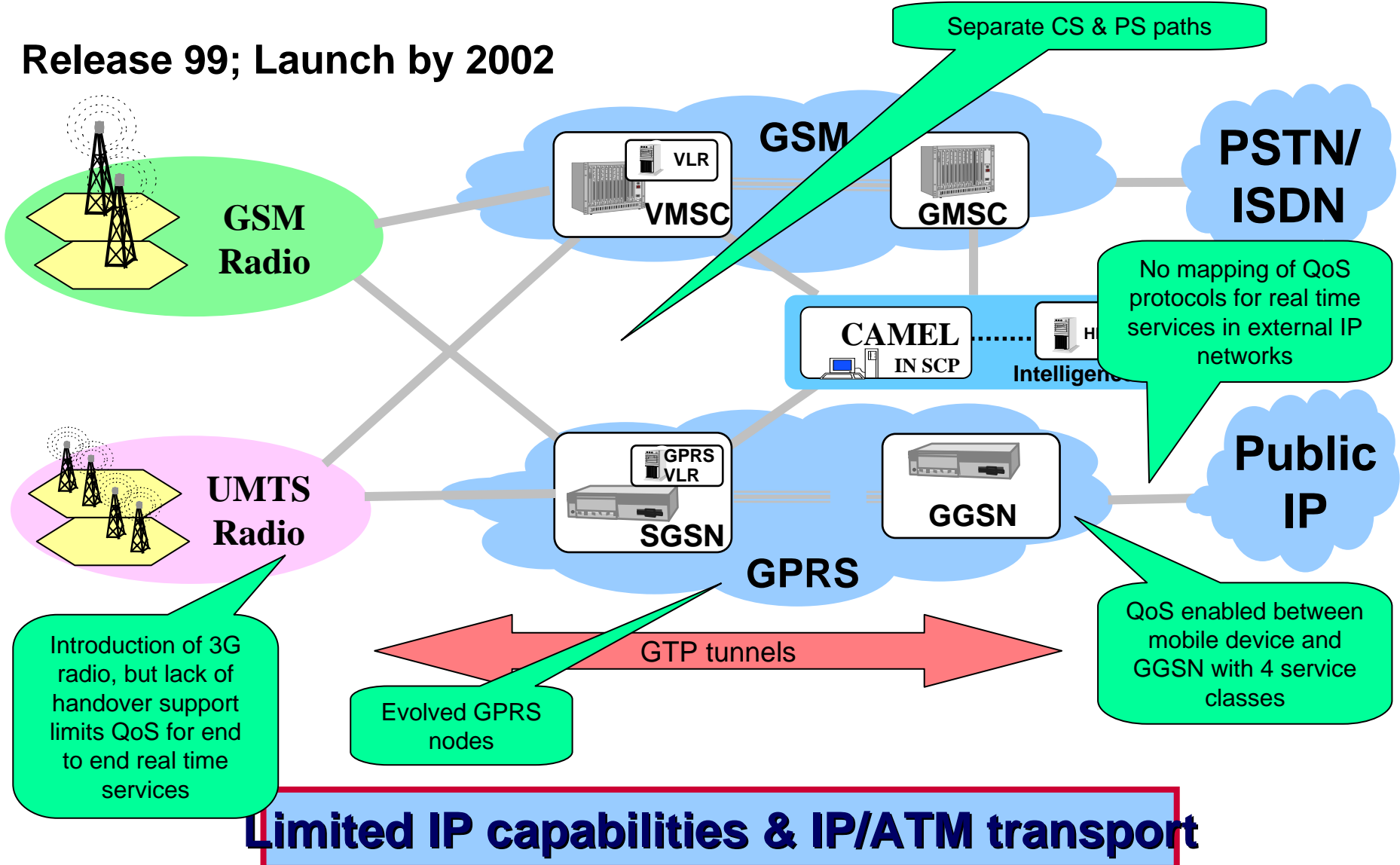

Introduction of 3G radio, but lack of handover support limits QoS for end to end real time services

Evolved GPRS nodes

QoS enabled between mobile device and GGSN with 4 service classes

No mapping of QoS protocols for real time services in external IP networks

Separate CS & PS paths

Limited IP capabilities & IP/ATM transport

Mobile Network Architecture

BT wireless

Evolution

Release 4/5; Launch by 2003/4

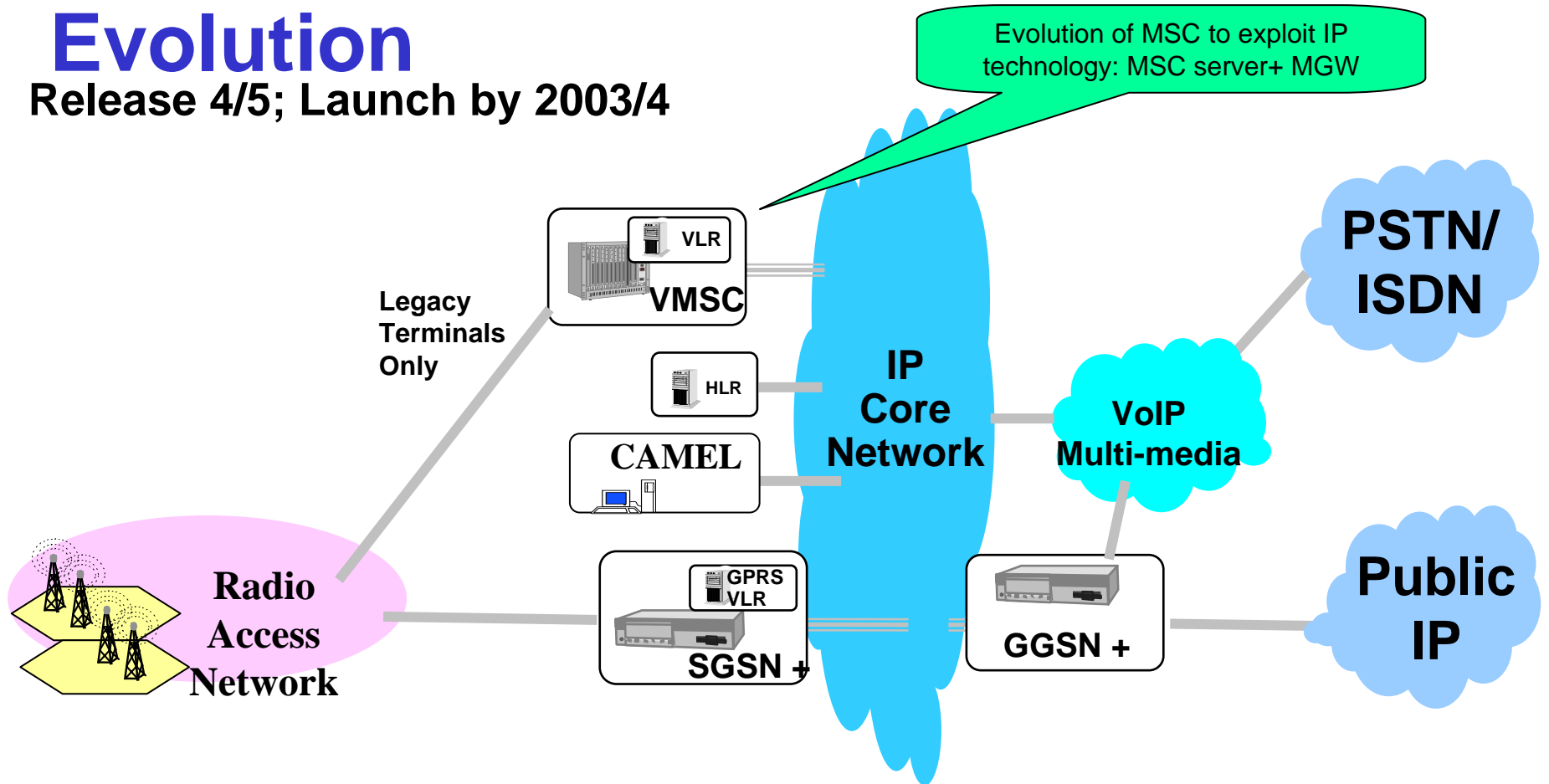

**Growth of Voice & Data over IP,
Limit CS / MSC to legacy terminals only**

'Mobile' VoIP & Multi-Media

IM Domain

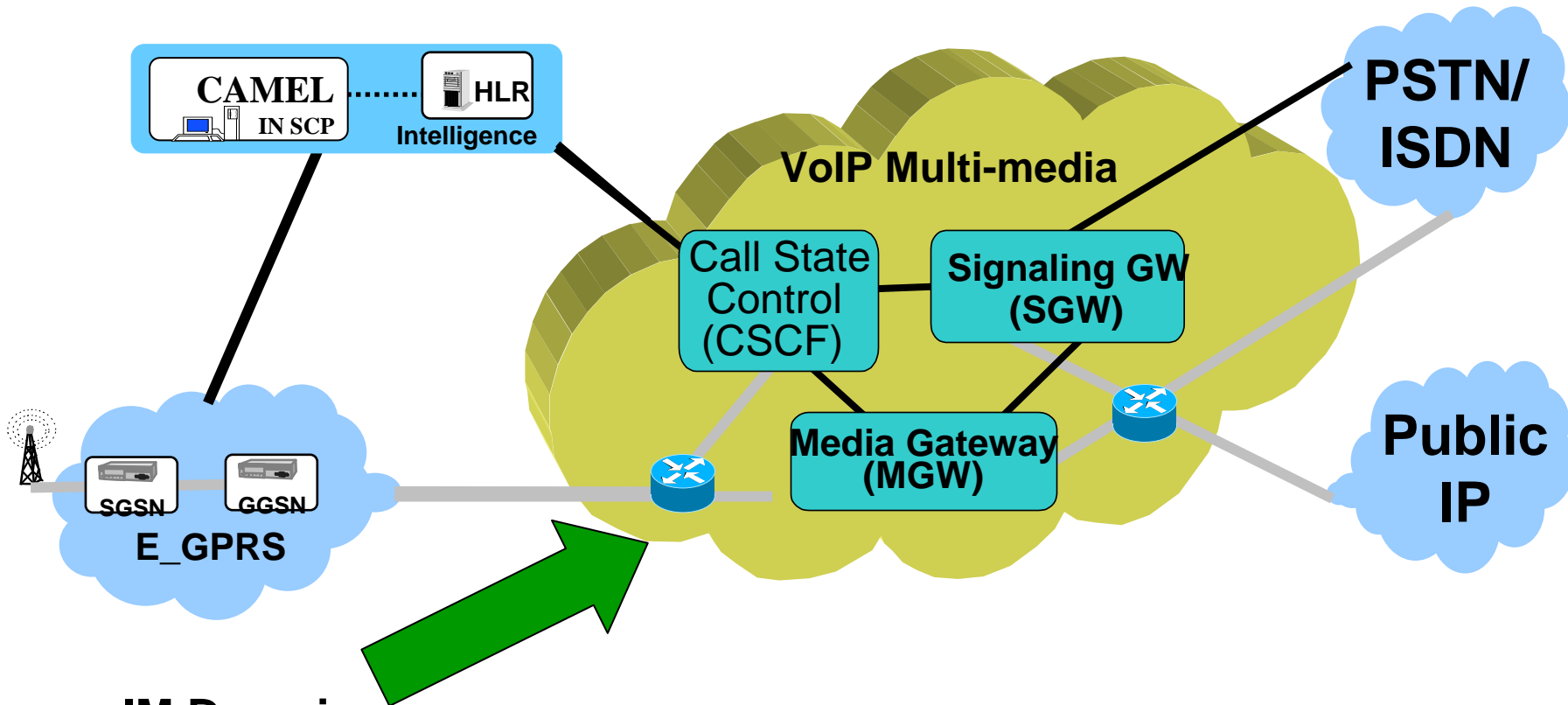

IM Domain:

- 3G mobile network domain for real-time services
- Signaling is between mobile & CSCF
- User plane is between mobile & MGW

IPv6 and SIP for IM Domain

BT wireless

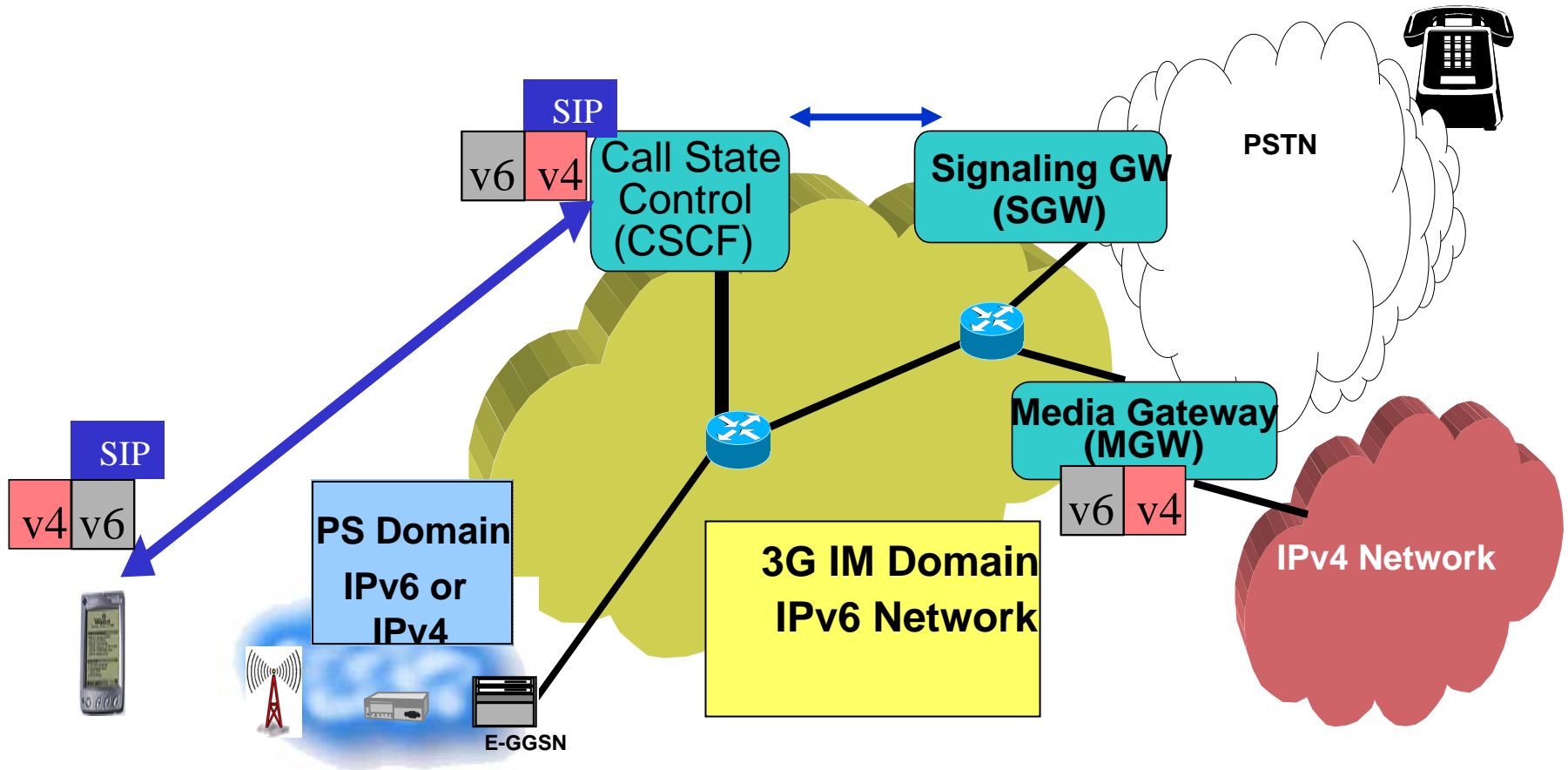

- Since IM Domain is brand new, we want it to be IPv6 only
- PS Domain can transition from IPv4 to IPv6 depending on requirements / economics
- SIP is critical signaling protocol to realize the IP-based real-time mobile services

Release 4/5 Features

- Tied to progress of 3GPP standardisation
- Release 4 offers full QoS engineering:
 - Handover and SRNS relocation procedures
 - End to end QoS protocols (Diffserv, RSVP) for interworking with external IP networks
 - Mapping between SIP SDP attributes and GTP service classes
- Release 5 is first potential IM Domain implementation
- Integrates voice/data on a common IP core
- Adaptation of IETF standard protocols
- Roaming support
- MGW for interworking with external CS networks

Standards are coming in phases & slow in coming!

Wired & Wireless parallel evolution

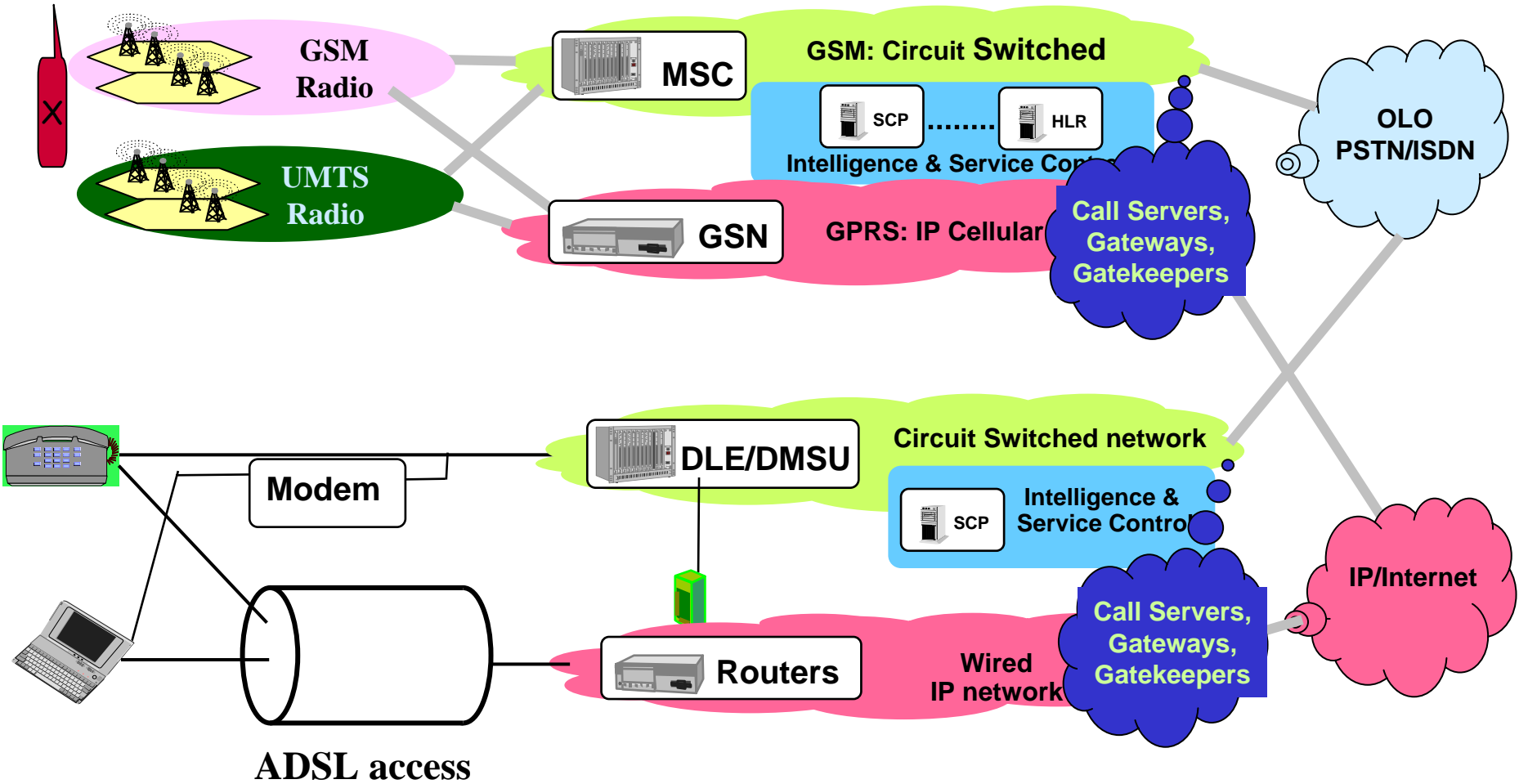

VoIP: Wireless (R54/5) & Wired

Release 6+ PS domain

BT wireless

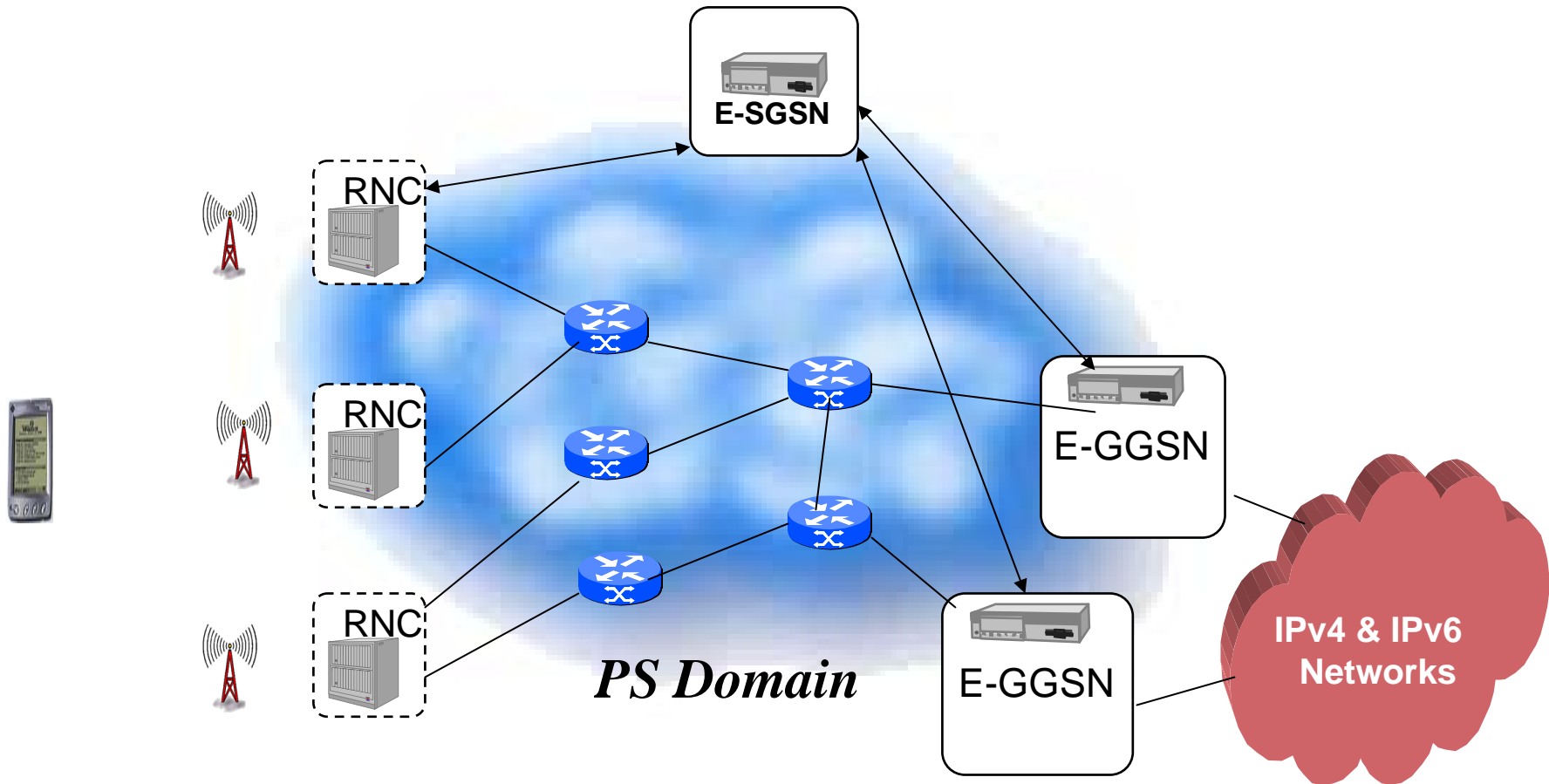

Separation of SGSN into server for control and mobility enabled router for traffic

BT Wireless Perspective on VoIP

- New revenue generating services versus cost reduction
- Mobile Multimedia over IP versus VoIP
- Mobile operators can retain more value-add as there is need for QoS & other functions over the air interface
- SIP signalling versus H.323
- IPv6 versus IPv4
- Dual stack IPv4/v6 mobile devices
- Gateways have to support IPv6, SIP and various mobile transcoders
- SIP servers have to support
 - mobility interactions with devices & home servers
 - billing stats for roaming purposes
 - interactions with SGSN & GGSN nodes in addition to routers
- Support for R99 CS devices / services
- Support for international roaming

Mobile networks require additional capabilities for VoIP

Technology Collaborations on IM Domain

BT *wireless*

- **Launching a technology collaboration with Nokia focusing on IP Multimedia (IM) Domain**
- **Objective: early opportunity to evaluate feasibility of**
 - SIP for mobile signalling,
 - IPv6 in IM domain as well as IPv4/v6 dual stacks,
 - IP compression over the air,
 - interworking with PSTN and other networks,
 - legacy support for R99 CS devices / services, and
 - roaming capabilities for mobile real-time applications over IP.
- **Phases and Timeframes**
 - Phase 1 - Experimental system, based on simulation of components - 1Q 2001
 - Phase 2 - Pilot system - 2H 2001
 - Pre-commercial system - 1Q 2002

Earliest opportunity to engage in leading-edge technology

Major Challenges

- **Technology challenges**
 - Standardisation
 - End-to-end QoS
 - Over-the-air IP efficiency (IP header compression)
 - Various types of interworkings
 - OSS, billing and other systems
 - Others?
- **Business Challenges**
 - Compelling mobile multimedia applications development
 - Customer expectation management
 - Others?

Need collaborations and leveraging of work